

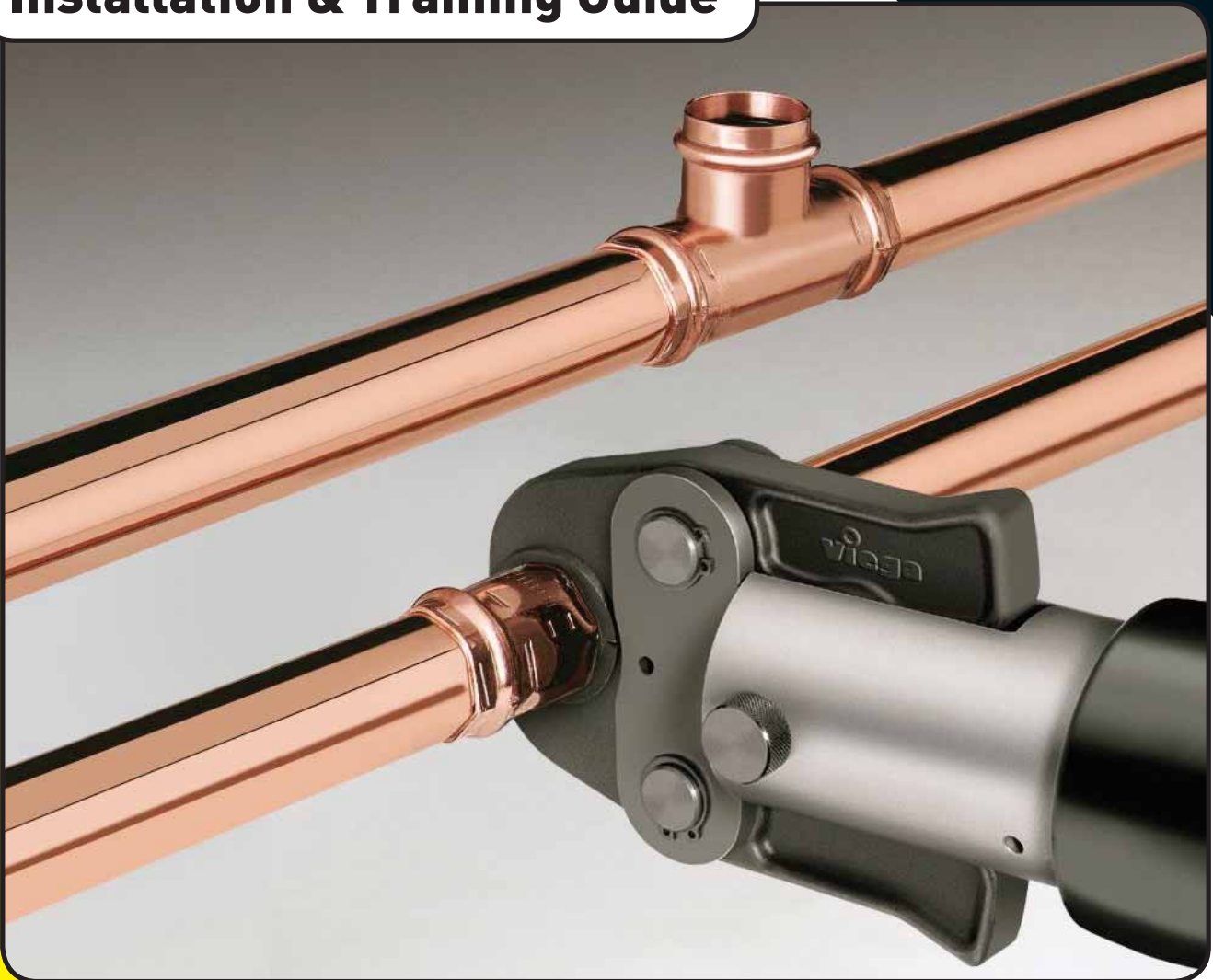

Crane Copper Tube

**Propress™
GAS**

Installation & Training Guide



viaga

Index

Section	Page
1.0 Introduction	2
2.0 Product Description	3
3.0 Pressing Process Overview	7
4.0 Installation Requirements	8
5.0 Installation Procedure	12

1.0 Introduction

1.1 The Viega Propress™G System

For many years copper tubing has been used for gas piping systems because of its excellent performance. Copper tubing is widely used for liquefied petroleum (LP) and natural gas (NG) piping systems. Australian Standard AS5601, "Gas installations" permits copper tube to AS1432 Type A and B to be used for pressure applications up to 200kPa. Brazing (not soldering), flanges and compression joints have been the traditional methods for joining copper tubing.

With the Australian approval of copper Propress™G fittings for gas piping systems, another viable joining method is available for copper tubing. Propress™G fittings will allow for a faster, lower cost, joining method for gas piping.

Viega, the company that developed the Propress™G system, has over 15 years of experience using press connect fittings in gas piping systems. The Viega fittings have been approved in Europe for many years for gas piping system. The lower cost installation has resulted in extensive use of copper gas piping systems using press connect fittings.

Viega Propress™G fittings used for gas installations are similar to the Propress fittings used in water piping systems. There are two main differences between Propress™G (gas) fittings and Propress (water) fittings.

The sealing element for the Propress™G fittings is yellow and is made of Hydrogenated Nitrile Butadiene Rubber (HNBR). Test results have shown that this sealing element can maintain a gas tight seal at temperatures up to 427°C.

The Propress™G fittings also incorporate the Viega patented SC (Smart Connect) feature. This feature will allow air to leak through the fitting during testing if the fitting has not been pressed. When the fitting is pressed, the SC feature is closed forming a permanent leak proof connection. Viega Propress™G fittings also have a yellow dot and the word GAS printed on the outside of the fitting to visually indicate that the fittings are intended for gas systems. Fittings not having the yellow marking must never be used for gas piping systems.

1.2 Approvals and Certifications

Viega Propress™G has been included in the Australian Standard AS5601 "Gas Installations" as fittings for gas pipe.

Viega Propress™G is approved by three major International codes and standards regulating gas piping systems. These do not apply to Australian installations, but are as follows:

- The National Gas Code also identified as NFPA 54.
- The ICC International Gas Code.
- The IAPMO Uniform Plumbing Code.

All three of these Codes regulate both natural gas and LP gas piping systems internationally. In the US, Viega Propress™G fittings have been listed for use in gas piping systems by CSA.

1.3 Propress™G Advantages

The advantages of installing copper gas lines using Propress™G fittings include:

- Ultra fast assembly and pressing of joints.
- Improved on-site safety and ease of use with no brazing, soldering or gluing required, and no need to drag gas bottles and hoses around the site.
- Single action pressing produces a reliable permanent joint in seconds and reduces the risk of leaking joints and the need for remedial work.
- No special certification is required for installers – installer must be an approved gasfitter and gain Crane Copper Tube accreditation.
- Approved for use throughout Australia, and also complies with international codes.
- Convenient easy to use portable battery powered pressing tool reduces on-site equipment and allows easy access even in tight or hard to reach locations.

- Cost-effective for both low and high pressure gas line systems. Excellent for retro-fit and remodelling gas line installations. Can be connected to existing copper lines.
- Can be used on AS1432 Type A and B copper tube from DN15 to DN100.
- Crane copper tube and a comprehensive range of fittings is readily available throughout Australia.
- Technical field support provided by Crane Copper Tube representatives.
- Propress™G fittings do not reduce the bore size, and the fittings provide bend radii that are larger than traditional capillary fittings. Flow calculations can be made as per capillary fittings.
- Can be used behind or in walls, direct sunlight and underground
- Cylindrical tube guides to protect sealing element during assembly.
- 'Smart Connect' leak detection feature makes un-pressed fittings easy to find. Obvious pressing marks also make it easy to identify un-pressed fittings.
- When used with Crane copper tube, Viega Propress™G fittings are guaranteed for 25 years, and have a design life of over 50 years.
- One pressing tool can be used for both gas and water installations.

1.4 Applications

Propress™G is widely used for gas applications due to its excellent resistance to corrosion, and its ease of handling and installation. Copper has provided reliable service for several decades and offers effective solutions to today's technological challenges.

The Propress™G fittings are provided with a HNBR sealing element, which can accommodate temperatures of -40°C to 70°C and a maximum operating pressure of 1600kPa, making them suitable for many applications. Applications for Propress™G include the following:

- Natural Gas
- LP Gas
- Mixed Gases
- Fuel Oil (for heating applications)

Note: Consult the Crane Copper Tube Technical Support Department before installing the system in other applications, or applications where temperatures and/or pressures are outside the stated ratings.

2.0 Product Description

2.1 Propress™G Fittings

Propress™G DN15 to DN100 fittings are manufactured in Copper and Bronze which offers outstanding ductility, durability and corrosion resistance. In addition to these outstanding material properties, the Propress™G fittings also offer the following features:

- Unique SC 'Smart Connect' leak detection system which greatly improves line testing procedures.
- Press-fitting geometry designed to ensure reliable connections.
- Integral stop for defined insertion depth.
- Factory-fitted high-performance HNBR sealing element.

The pressing process reshapes the fitting in the area of the sealing element ensuring continuous contact between the fitting, tubing, and the sealing element. Propress™G fittings are suitable for a wide variety of residential and commercial gas piping installations.

For a detailed listing of available fittings, refer to the product data sheets, supplied separately.

2.2 HNBR Sealing Element

Propress™G press fittings are manufactured with a high quality HNBR sealing element installed at the factory. This sealing element is used mainly for applications of natural, propane, mixed, and manufactured gases, and can be used in fuel oil systems.

Definition: HNBR – Hydrogenated Nitrile Butadiene Rubber. The seal is yellow in colour with an operating temperature of -40°C to 70°C. HNBR is widely known for its physical strength and retention of properties after long-term exposure to heat, oil, and chemicals.

The unique properties attributed to HNBR have resulted in wide adoption of HNBR in automotive, industrial, and assorted performance-demanding applications (e.g. engine seals, grommets, and gaskets); fuel system seals and hoses; transmission system, bonded piston seals; oil field packers, and rotary shaft seals. With its excellent performance for the most demanding of applications HNBR is the ideal choice for applications needing excellent physical properties, as well as oil, heat, and/or chemical resistance.

The HNBR sealing element is not suitable for food contact applications and **cannot** be installed in drinking water applications.

2.3 Copper Tube

Crane copper tube has been tested and approved for use with the Viega Propress™G system. When installed to specifications on Crane copper tube, Propress™G fittings are guaranteed for 25 years against leaks, faulty materials and manufacture. Refer to Tables 2.3.1 and 2.3.2.

Propress™G gas installations can be made with corrosion resistant copper tube complying with the requirements of AS1432 Type A and Type B. Type A and B copper tube (AS1432), have been used in gas systems for many years. Usually, Type B is used for interior distribution systems and Type A for any underground lines. The dimensions of copper tube used for gas installations are shown in Table 2.3.1 and 2.3.2.

The “Gas installations” Australian Standard AS5601 permits the use of AS 1432 Type A or Type B copper pipe for pressures up to 200 kPa in above and below ground applications. Where higher pressures apply, approval must be obtained from the Technical Regulator. Copper piping is not permitted beneath a building at gas

pressures exceeding 7kPa unless plastic coated or covered with a proprietary wrapping acceptable to the Technical Regulator.

Under normal Australian conditions, Propress™G and copper tubing can also be installed outside without any additional corrosion protection. However, where potential aggressive environments exist, precautions should be taken to protect the entire length of piping.

In residential applications, copper tubing with Propress™G fittings can be used to run gas from the meter or source to furnaces, boilers, gas ranges, water heaters, gas fireplaces, outdoor barbecues, and decorative lighting.

Propress™G fittings are allowed to be installed underground, but it is always good practice to avoid this whenever possible. Copper tubing is available in long lengths and coils, reducing the number of fittings required.

Copper piping should not be placed in direct contact with metal roofs due to the potential for corrosion of the roof material. In such cases, the copper should be raised off the roof with suitable clips. Also, in the event that piping may be exposed to large fluctuations in temperature, at the design stage, provision must be made to accommodate the anticipated expansion and contraction forces that will be imposed on the system.

Crane Copper Tube Specifications

Table: 2.3.1

Type A - Copper Tube to suit Viega PropressG Fittings										
Crane Item Number	Nominal Size	Outside Diameter (mm)	Wall Thickness (mm)	Min. Wall Thickness (mm)	Imperial Equivalent O.D. and swg	Nominal Weight (kg/m)	Form	Temper	Safe Working Pressure (kPa) @ ≤50°C	Safe Working Pressure (kPa) @ >50 & ≤75°C
50103075	DN 15	12.70	1.02	0.88	1/2" x 19	0.335	18mcoil	Annealed	6100	5060
50103076	DN 15	12.70	1.02	0.88	1/2" x 19	0.335	6mstraight	Bendable	6100	5060
50103139	DN 18	15.88	1.22	1.04	5/8" x 18	0.502	6mstraight	Hard drawn	5750	4770
50103177	DN 20	19.05	1.42	1.21	3/4" x 17	0.703	18mcoil	Annealed	5560	4610
50103179	DN 20	19.05	1.42	1.21	3/4" x 17	0.703	6mstraight	Bendable	5560	4610
50103178	DN 20	19.05	1.42	1.21	3/4" x 17	0.703	6mstraight	Hard drawn	5560	4610
50103230	DN 25	25.40	1.63	1.39	1" x 16	1.088	18mcoil	Annealed	4750	3940
50103231	DN 25	25.40	1.63	1.39	1" x 16	1.088	6mstraight	Hard drawn	4750	3940
50103271	DN 32	31.75	1.63	1.39	1 1/4" x 16	1.379	6mstraight	Hard drawn	3750	3110
50103293	DN 40	38.10	1.63	1.39	1 1/2" x 16	1.670	6mstraight	Hard drawn	3100	2570
50103321	DN 50	50.80	1.63	1.39	2" x 16	2.251	6mstraight	Hard drawn	2310	1910
50103348	DN 65	63.50	1.63	1.39	2 1/2" x 16	2.832	6mstraight	Hard drawn	1840	1520
50103360	DN 80	76.20	2.03	1.73	3" x 14	4.229	6mstraight	Hard drawn	1900	1580
50103372	DN 100	101.60	2.03	1.83	4" x 14	5.677	6mstraight	Hard drawn	1500	1250

Annealed
 Bendable

Table: 2.3.2

Type B - Copper Tube to suit Viega PropressG Fittings										
Crane Item Number	Nominal Size	Outside Diameter (mm)	Wall Thickness (mm)	Min. Wall Thickness (mm)	Imperial Equivalent O.D. and swg	Nominal Weight (kg/m)	Form	Temper	Safe Working Pressure (kPa) @ ≤50°C	Safe Working Pressure (kPa) @ >50 & ≤75°C
50103045	DN 15	12.70	0.91	0.77	1/2" x 20	0.301	18m coil	Annealed	5290	4390
50103047	DN 15	12.70	0.91	0.77	1/2" x 20	0.301	6m coil	Annealed	5290	4390
50103061	DN 15	12.70	0.91	0.77	1/2" x 20	0.301	6m straight	Bendable	5290	4390
50103133	DN 18	15.88	1.02	0.88	5/8" x 19	0.426	18m coil	Annealed	4810	3990
50103135	DN 18	15.88	1.02	0.88	5/8" x 19	0.426	6m straight	Bendable	4810	3990
50103164	DN 20	19.05	1.02	0.88	3/4" x 19	0.517	18m coil	Annealed	3970	3290
50103165	DN 20	19.05	1.02	0.88	3/4" x 19	0.517	6m straight	Bendable	3970	3290
50103222	DN 25	25.40	1.22	1.04	1" x 18	0.829	18m coil	Annealed	3500	2900
50103225	DN 25	25.40	1.22	1.04	1" x 18	0.829	6m straight	Hard drawn	3500	2900
50103268	DN 32	31.75	1.22	1.04	1 1/4" x 18	1.046	6m straight	Hard drawn	2780	2300
50103291	DN 40	38.10	1.22	1.04	1 1/2" x 18	1.264	6m straight	Hard drawn	2300	1910
50103319	DN 50	50.80	1.22	1.04	2" x 18	1.699	6m straight	Hard drawn	1710	1420
50103339	DN 65	63.50	1.22	1.04	2 1/2" x 18	2.134	6m straight	Hard drawn	1370	1130
50103358	DN 80	76.20	1.63	1.39	3" x 16	3.414	6m straight	Hard drawn	1520	1260
50103369	DN 100	101.60	1.63	1.47	4" x 16	4.577	6m straight	Hard drawn	1200	1000

Annealed
 Bendable

2.4 Pressing Tools

The Viega Picco and Pressgun Picco tools are compact, lightweight yet powerful battery-powered electro-hydraulic tools for press-fit joining of Propress™ gas and water installations using DN15, DN18, DN20 and DN25 fittings. (The jaws are not interchangeable with the PT3/4B models).

The Viega PT3 and Pressgun 4B tools will press DN15 to DN100 Propress™G gas and Propress™ Water fittings. (The jaws are not interchangeable with the Picco series tools).

Automatic forced compression, electronic monitoring of bolt safety and temperature, plus battery charge level and service interval display, all make working with the Viega Propress™ tool easy, quick, and so dependable.

The Viega Propress™ tools also provide easy access to hard to reach joints as the head can be rotated. Picco and PT3 heads can rotate up to 90°, while Pressgun Picco and 4B heads can rotate up to 180°.

The Viega pressing tools are manufactured in Switzerland by Von Arx AG, which also manufactures pressing tools sold under the RIDGID® brand name.



Viega Pressgun Picco



Viega Pressgun 4B

2.5 Safety

The Viega pressing tools are power tools that need to be used in accordance with these instructions and all of the recommendations which accompany the tool. Under no circumstances should the pressing tools be used for anything other than their intended use.

2.6 Fittings Packaging

Propress™G fittings are supplied in a colour coded bag (yellow) to indicate that they are intended for gas use and are labeled to indicate fitting type and size. For a detailed listing of available fittings, refer to the product data sheets, supplied separately.



3.0 Pressing Process Overview

3.1 The 'Smart Connect' (SC) Feature

Propress™G fittings incorporate the unique Viega 'Smart Connect' feature. The fittings are designed with a special indentation in the inside surface of the fitting across the sealing element. The purpose of this indentation is to provide a positive leakage point during testing, allowing air past the sealing element of an unpressed connection.

The indentation is closed during the pressing process creating a leak free permanent connection. This feature provides quick and easy identification of connections, which have not been pressed prior to putting the system into operation. Unpressed connections are located by pressurizing the tubing system with a pressure range of 2.2 - 650kPa. The SC feature test can be conducted at the same time as the final pressure test as specified in AS5601, which is well within this range.

Figure: 3.1.1 SC Feature of a Propress™G fitting

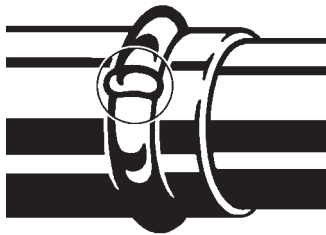

3.2 Removable Tag

Viega Propress™ XL fittings (DN65, DN80 and DN100) are also fitted with removable tags. These tags are to be removed after a fitting is pressed to indicate that the joint is completed.

Figure: 3.2.1

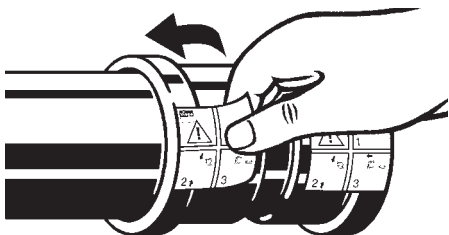

3.3 The Connection Process

The pressing process produces a permanent joint between the press fitting and the tubing in a matter of seconds. For Propress™G fittings (DN15 to DN50) this is achieved by creating a hexagonal indentation in front of and behind the HNBR sealing element on the press fitting. At the same time, the pressing process reshapes the fitting to encapsulate the sealing element. This positive/non-positive joint ensures a permanent leak-proof connection.

Figure: 3.3.1

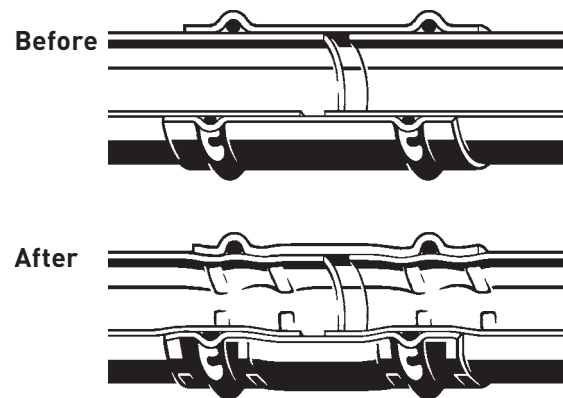

In the case of Propress™ XL fittings (DN65, DN80 and DN100), the pressing process reshapes the fitting in the area of the sealing element and grip ring, ensuring continuous contact between the fitting, grip ring teeth and tubing, and between the fitting, sealing element and tubing.

Figure: 3.3.2

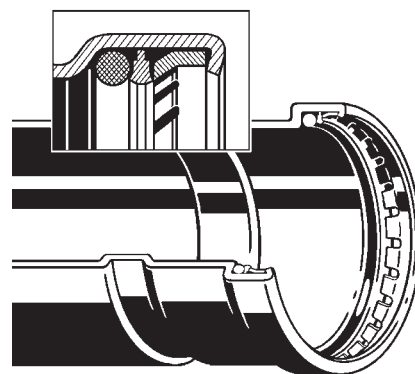

4.0 Installation Requirements

4.1 License and Training

All Propress™G installations must be carried out by a licensed gas fitter with appropriate Propress™G training and accreditation. For information on Propress training contact Crane Copper Tube.

4.2 Minimum Clearance Requirements for the Pressing Process.

The minimum clearance required between two tubes and between the tubing and any permanent structure must be taken into consideration. The minimum allowable values are specified in Tables 4.2.1 to 4.2.5.

Table: 4.2.1 Minimum Clearance from a Surface and Adjacent Tubing for Pressing DN15 to DN50.

Tube Size DN (O.D)ø	Picco Series Tools		PT3/4B Tools	
	a	b	a	b
DN15 (1/2")	25	60	23	64
DN20 (3/4")	25	65	26	64
DN25 (1")	25	65	29	76
DN32 (1-1/4")	-	-	32	80
DN40 (1-1/2")	-	-	48	95
DN50 (2")	-	-	54	127

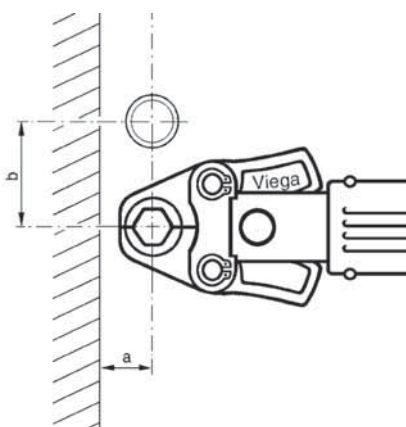

Table: 4.2.2 Minimum Clearance from a Surface and Adjacent Tubing for Pressing XL Fittings.

Tube Size DN (O.D)ø	a	b
	Minimum Clearance (mm)	
DN65 (2-1/2")	110	185
DN80 (3")	120	200
DN100 (4")	135	215

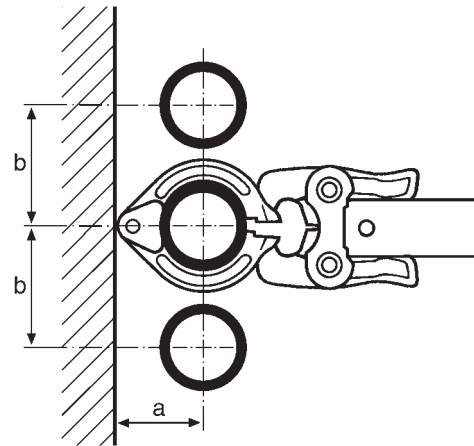

Table: 4.2.3 Minimum Clearance from Internal Corner Surfaces and Adjacent Tubing for Pressing DN15 to DN50.

Tube Size DN (O.D)ø	Picco Series Tools			PT3/4B Tools		
	a	b	c	a	b	c
DN15 (1/2")	30	40	70	23	35	64
DN20 (3/4")	30	40	75	26	38	64
DN25 (1")	30	40	80	29	45	76
DN32 (1-1/4")	-	-	-	32	57	80
DN40 (1-1/2")	-	-	-	48	64	95
DN50 (2")	-	-	-	54	80	127

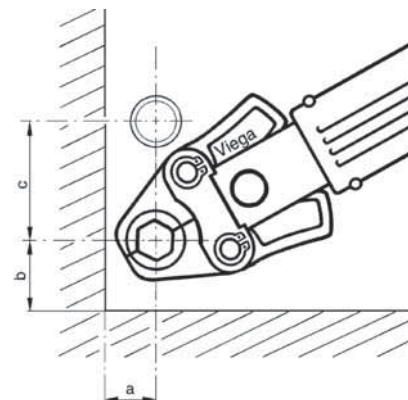

Table: 4.2.4 Minimum Clearance from Internal Corner Surfaces and Adjacent Tubing for Pressing XL Fittings.

Tube Size DN (O.D)ø	a	b	c
	Minimum Clearance (mm)		
DN65 (2-1/2")	110	185	130
DN80 (3")	110	185	130
DN100 (4")	135	215	155

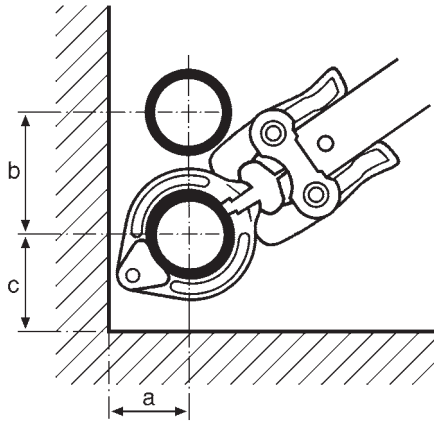
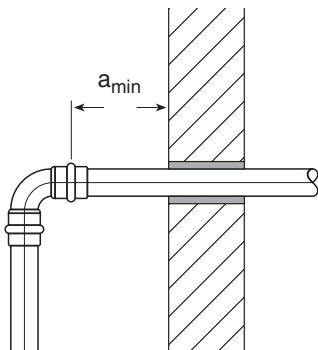

Table 4.2.5 Minimum Clearance Requirements for the Pressing Process in Front and/or Behind Structural Components.

Tube Size DN (O.D)ø	Minimum Clearance 'a' min. (mm)	
	Picco Series Tools	PT3/4B Tools
DN15-DN25 (1/2" - 1")	35	50
DN32-DN100 (1 1/4" - 4")	-	50



4.2.6 Minimum Clearance Between Two Propress™ Connections.

To ensure proper sealing of the press connections the minimum spacing between Propress™ connections must be maintained as per Table 4.2.6.

Note: For installations where the minimum distance is 0 it is particularly important to ensure the correct insertion depth of the tubing into each fitting.

Table 4.2.6

Tube Size DN (O.D)ø	Minimum Clearance a (mm)
DN15 (1/2")	0
DN20 (3/4")	0
DN25 (1")	0
DN32 (1-1/4")	10
DN40 (1-1/2")	15
DN50 (2")	20
DN65 (2-1/2")	15
DN80 (3")	15
DN100 (4")	15

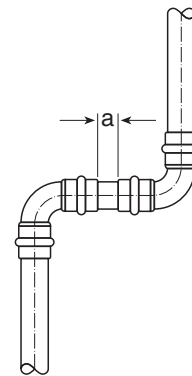

4.2.7 Minimum Clearance Between a Propress™ Fitting and an Existing Brazed Fitting

To ensure proper sealing of both the brazed and Propress™ fitting, the minimum distance must be maintained between the two fittings as per Table 4.2.7.

Table 4.2.7

Tube Size DN (O.D)∅	Minimum Clearance 'a' (mm)
DN15 (½")	6
DN20 (¾")	6
DN25 (1")	10
DN32 (1-¼")	10
DN40 (1-½")	15
DN50 (2")	20
DN65 (2-½")	15
DN80 (3")	15
DN100 (4")	15

Note: It is particularly important that there is no residual solder or other foreign debris on the tubing to be inserted into the Propress™ fitting.

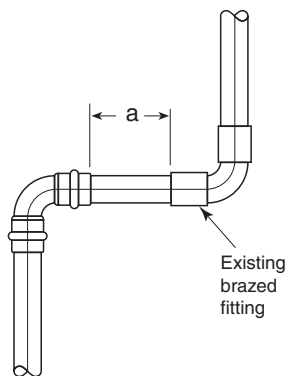

4.2.8 Minimum Clearance Between a New Brazed Fitting and an Existing Propress™ Fitting.

Note: Brazing near existing Propress™ fittings is not recommended and should be avoided.

To ensure proper sealing of both the brazed and press connections a minimum spacing between connections must be maintained. It is important to ensure that the tube inside the Propress™ fitting as well as the fitting itself are not subject to excessive heat when brazing.

It is recommended that brazing does not occur closer than a distance of 25 tube diameters from an existing press fitting. If this is not possible, then the installer must take proper precautions to keep the Propress™ connection cool while brazing (i.e. wrap the connection in a cold wet rag; fabricate brazed connection prior to installation; applying spray type spot freezing product). Table 4.2.8 shows the minimum clearance between a new brazed fitting and an existing Propress™ fitting.

Table: 4.2.8

Tube Size DN (O.D)∅	Minimum Clearance 'a' (mm)
DN15 (½")	318
DN20 (¾")	477
DN25 (1")	635
DN32 (1-¼")	807
DN40 (1-½")	968
DN50 (2")	1291
DN65 (2-½")	1625
DN80 (3")	2000
DN100 (4")	2500

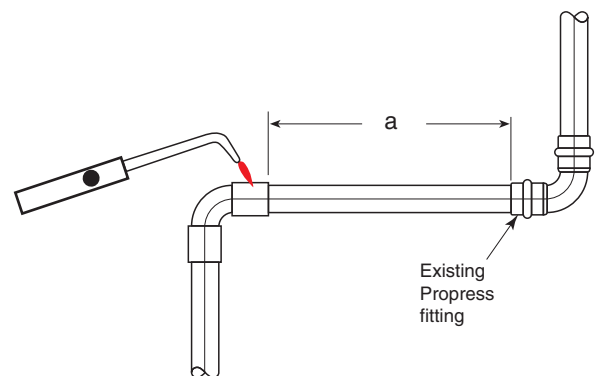

4.3 Tubing Supports

These instructions are in addition to the requirements clause 4.3 of AS5601.

Tube fixing clips perform two functions. One function is to provide support for the tubing system. The second function is to guide the tubing during expansion and contraction changes in the length of the tubing due to changes in temperature. Standard tubing clips can be used to support the tubing. Excessively large spacing between hangers may result in vibration and subsequent noise. Refer to AS5601 for the standard support spacing.

4.3.1: Spacing of Fixing Clips next to a Change in Direction.

Where a large amount of expansion or contraction is expected, fixing clips should not be placed within 100mm of a Propress™ fitting.

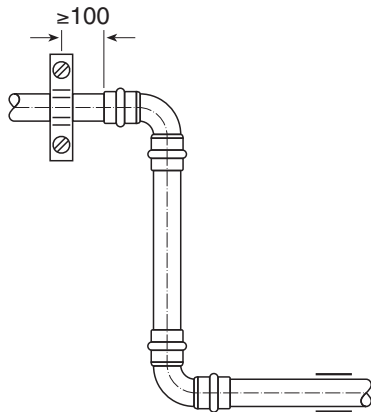

4.3.2: Spacing of Fixing Clips next to a Change in Direction.

Due to expansion or contraction, a fixing clip placed at right angles could unintentionally fix the pipe. Where a large amount of expansion or contraction is expected, fixing clips should not be placed within 250mm of fittings at a change in direction.

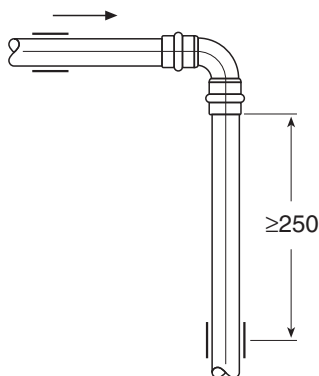

4.4 Cutting Tubing

Copper tubing can be cut to length with a tube cutter or a fine-toothed metal saw. It is not acceptable to cut the tubing with an abrasive cutting wheel or torch. The tubing ends must be deburred both on the inside and outside prior to insertion into the press fitting.

Note: When using Crane copper tube, incise marks present in the joint area will not affect the integrity of the seal. Incise marks in other tube products **MUST NOT** be present in the joint/cut area. Ensure the tube is defect free and that no foreign debris is present at the joint/cut location. Ensure the tube is round and not distorted after the cut has been made.

4.5 Threaded Adaptor

The Propress™G System can be connected with threaded fittings. When installing threaded connections, the threaded connection is to be completed first and then the press connection, to avoid unnecessary torsional stress.

4.6 Appliance Connections

Appliance connections are created by the installer using standard Propress™G fittings. The assembly is attached to a stud using standard tubing hangers for structural support. This provides a fixed point to attach a shut off valve and/or flexible appliance connector.

4.7 Pressure Testing

The pressure testing of installed tubing is to be completed in accordance with AS5601.

4.8 Tubing Exposed To Freezing Temperatures

In gas systems, Propress™G can be installed in ambient temperatures down to -40° C.

4.9 Propress™G Installation Caution Tag

All Propress™G installations are to be tagged at the gas meter with the approved label to indicate that the system has been installed with non-conventional fittings.

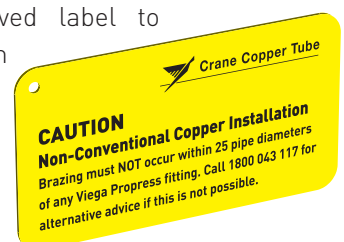

5.0 Installation Procedure

Installation shall be made in accordance with Australian Standard AS5601, and these installation instructions. All copper tube must comply with Australian Standard AS1432 - Copper tubes for plumbing, gas-fitting and drainage applications and be of Type A or B tube. The fittings are for use with gas in vapour state. The fitting/ tubing system shall not be used as a means of support, and any undue stress or strain on the fittings is to be avoided.

5.1 Installation Procedure for Propress™ Fittings DN15 to DN50.

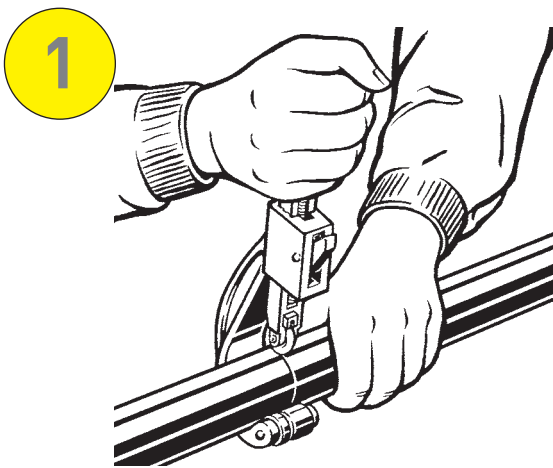

Cut the copper tube at right angles (using a tube cutter or fine-toothed steel saw).

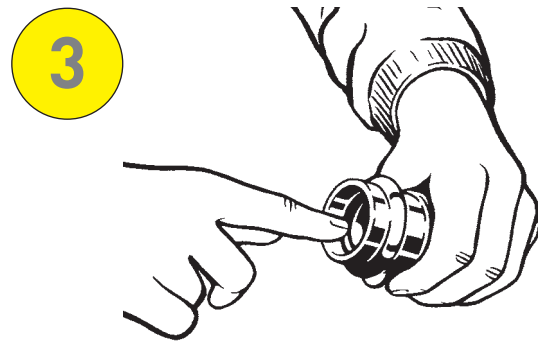

Check the sealing element is correctly seated within the fitting. (The sealing elements are already pre-lubricated so do not apply oil or lubricants). Use only the original Propress Yellow HNBR seals.

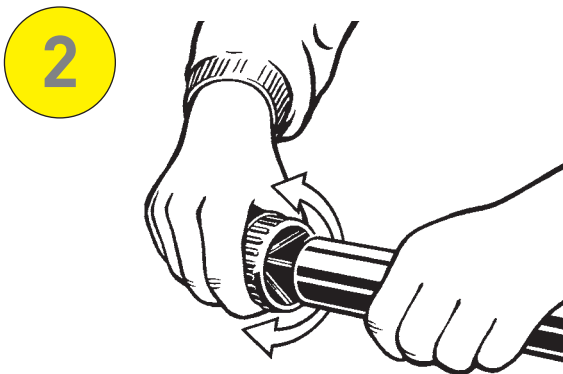

Deburr the end of the copper tube on both the inside and outside.

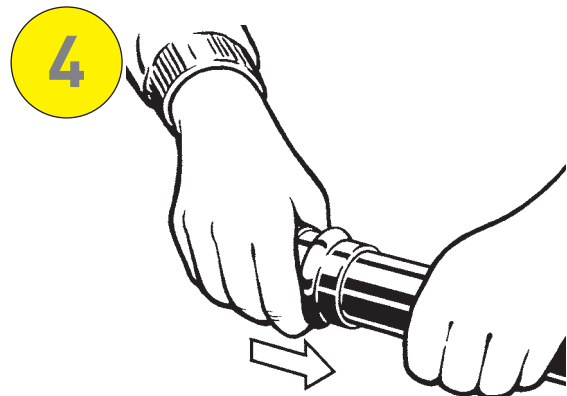

While turning slightly, slide the press fitting onto the tube until it stops

5

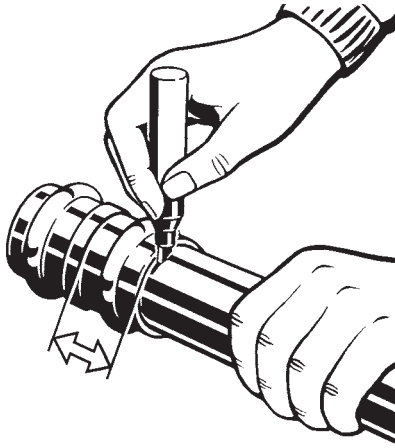

Mark the insertion depth.

8

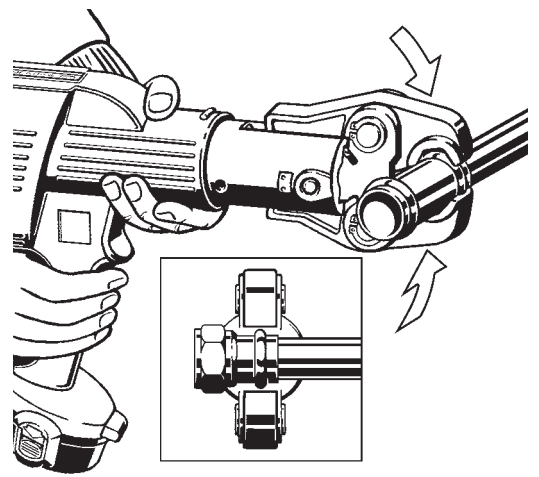

Check the insertion depth. Start the pressing procedure by holding the trigger until the ram has completed the cycle. Check the indication LEDs on the tool to ensure the pressing has been successful.

6

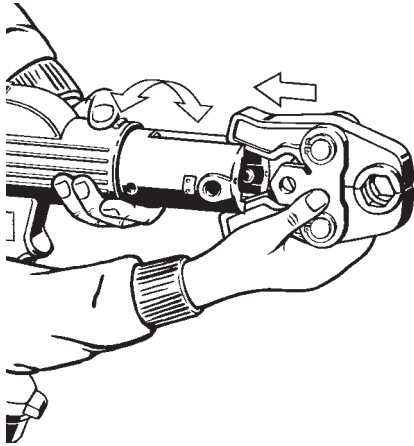

Insert the correct size jaws into the pressing tool and push the holding pin until it locks into place.

9

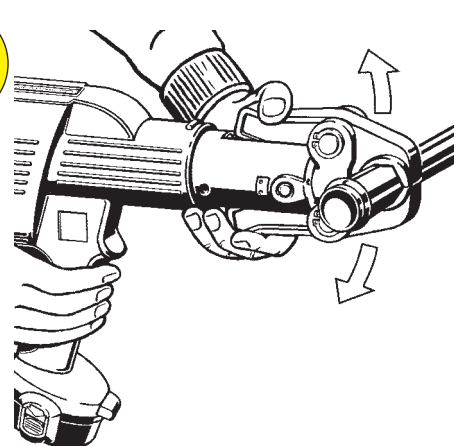

After completing the pressing procedure, open the jaws and withdraw the pressing tool.

7

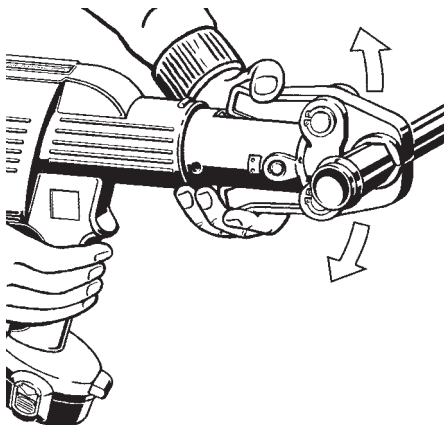

Open the jaws and place them onto the fitting so that the jaws are at right angles to the fitting.

5.2 Installation Procedure for Propress™ XL Fittings

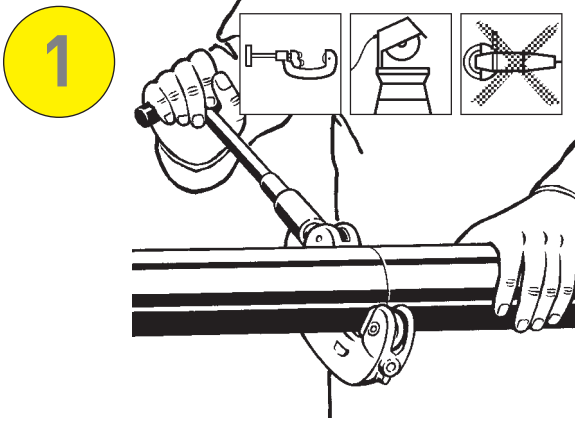

Cut copper tubing at right angles using displacement type cutter or fine-toothed steel saw.

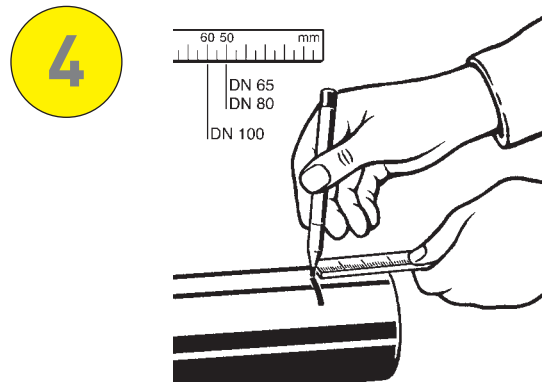

Mark the insertion depth.

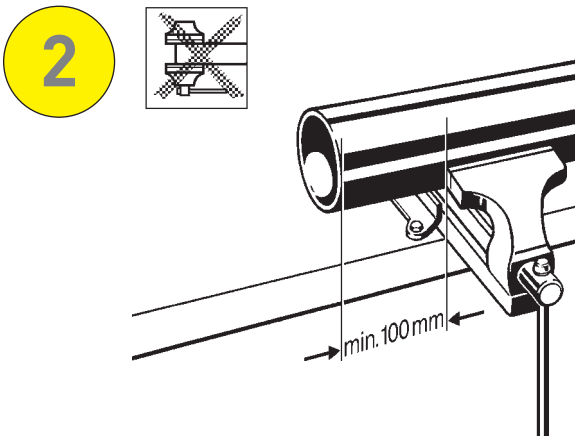

Keep end of tubing a minimum of 100 mm away from the contact area of the vice to prevent possible damage to the tubing in the press area.

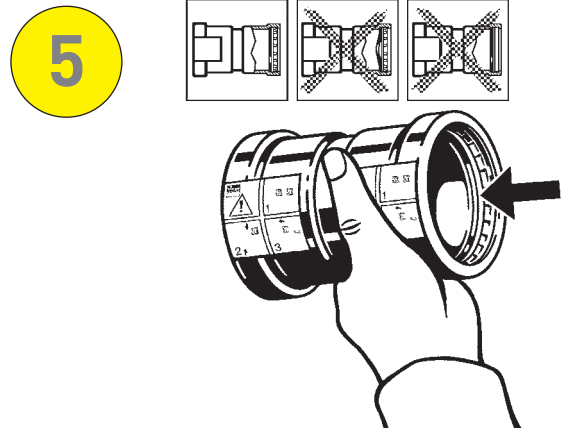

Use only Propress™G fittings with YELLOW markings. Check seal and grip ring for correct fit. (The sealing elements are already pre-lubricated so do not apply oil or lubricants, use clean water only if necessary).

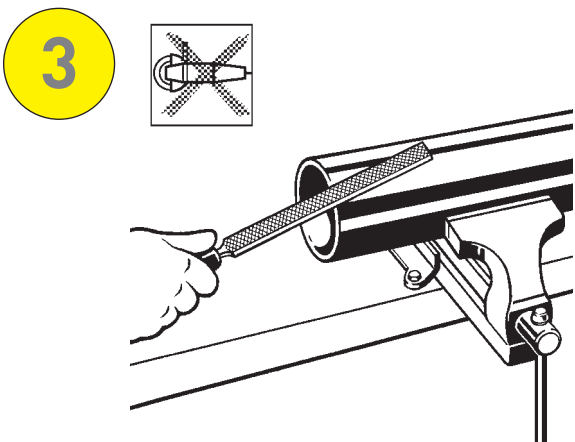

Deburr the inside and outside of tubing to prevent damage to the sealing element.

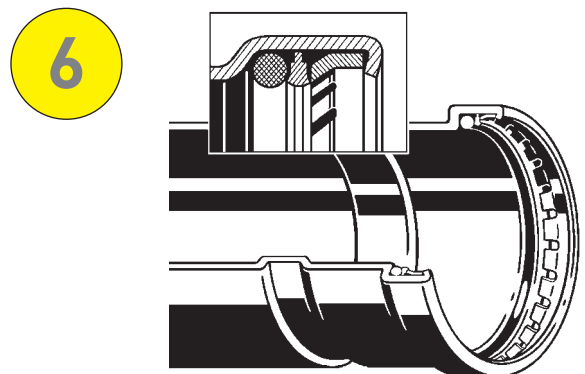
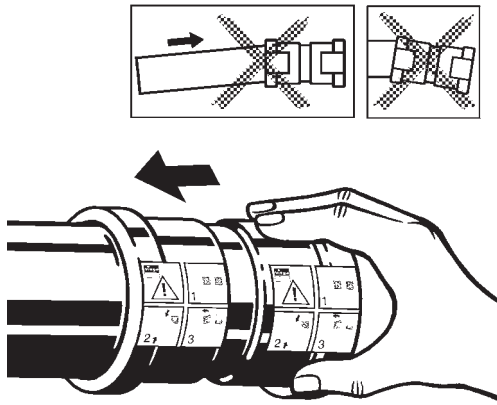

Illustration demonstrates proper fit of grip ring and sealing element. Use only Propress™G YELLOW sealing elements.

7



While turning slightly, slide press fitting onto tubing to the marked depth. Do not use oil or lubricants.

10

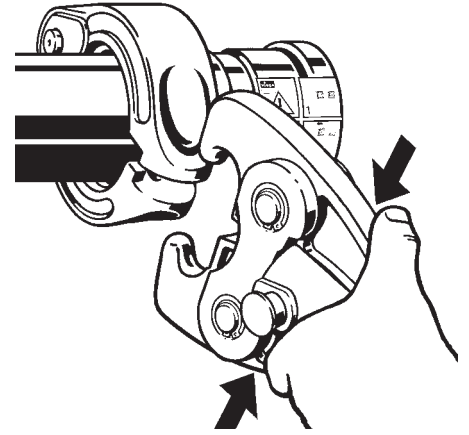

With V2 ACTUATOR fitted into the tool, open the V2 ACTUATOR as shown.

8



Propress™ XL fitting connections must be performed with Propress™ XL Rings and V2 ACTUATOR. See Viega Operator's Manual for correct tool instructions.

11

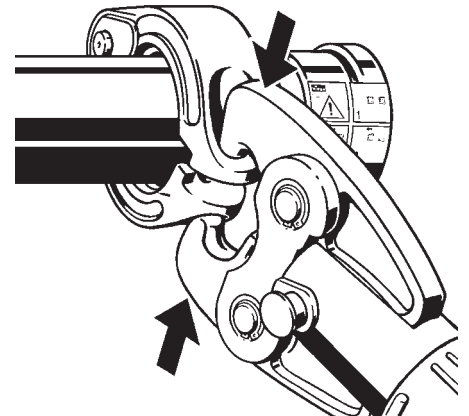

Place V2 ACTUATOR onto XL Ring and start the pressing process. Hold the trigger until the Actuator has engaged the XL Ring. Keep hands and foreign objects away from XL Ring and V2 ACTUATOR during pressing operation to prevent injury or incomplete pressing.

9

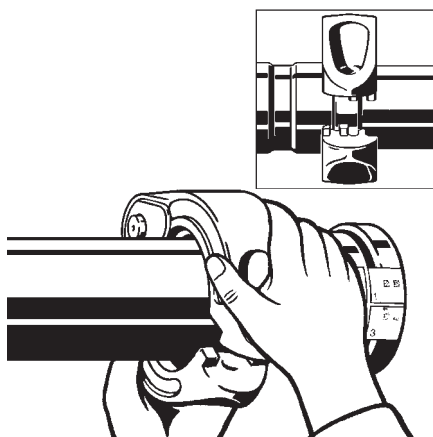

Open XL Ring and place at right angles on the fitting. XL Ring must be engaged on the fitting bead. Check insertion depth.

12

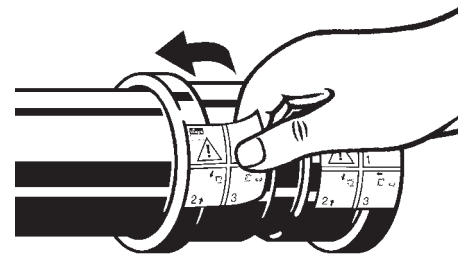

On completion of pressing, release V2 ACTUATOR from XL Ring and then remove the XL Ring from the fitting. Remove sticker from fitting to indicate joint pressing has been completed.



PropressTMG GAS



- Ultra fast installation.
- Permanent, strong, leak-free joints.
- No brazing, soldering or gluing required.
- Improves safety and efficiency.
- No need to drag gas bottles and hoses around the site.
- Approved for gas line installations Australia-wide.
- Cost effective for both low and high pressure installations.
- Can be used on type A and B copper tube.
- Proven track record with over 1 billion fittings in use worldwide.
- German precision engineered and manufactured fittings.
- Guaranteed for 25 years, with a design life of over 50 years.
- Superior pressure and temperature ratings .
- Can be used behind or in walls, direct sunlight and underground.
- Able to connect to existing copper lines.
- Cylindrical tube guide to protect sealing element during assembly.
- 'Smart Connect' leak detection feature to identify un-pressed fittings.
- Obvious pressing marks make it easy to see un-pressed fittings.
- One-piece fittings, ready for installation.
- Full flow joints (fittings maintain bore).
- Comprehensive range of fittings for both gas and water.
- One pressing tool can be used for both gas and water.
- Ease of use, yet tool is not cost effective for non professionals.

Information contained in this brochure is provided as a guide only. Crane Copper Tube does not warrant that the information is accurate or without errors or omissions. Crane Copper Tube reserves the right to correct any errors or misprints. All information and product details contained within this document are provided as a guide only. Product use shall be conducted by a fully licensed plumber/gas fitter.

Crane Copper Tube

ABN 51 008 408 151

A Division of Crane Enfield Metals Pty. Limited

PO Box 319, Penrith NSW 2751

Phone: 02 4720 5350

Fax: 02 4720 5390

sales@cranecopper.com.au

www.cranecopper.com.au

wCRN99709.BMS1210

